

# HARPER TRUCKS INC. MODEL - PGDK1635PO

## INSTRUCTIONS

### PARTS LISTING

P/N	QTY	DESCRIPTION
A	1	HEAD
B	2	SIDE FRAME
C	3	CROSSMEMBER
D	2	CASTER

600 LBS CAPACITY IN  
2-WHEEL POSITION

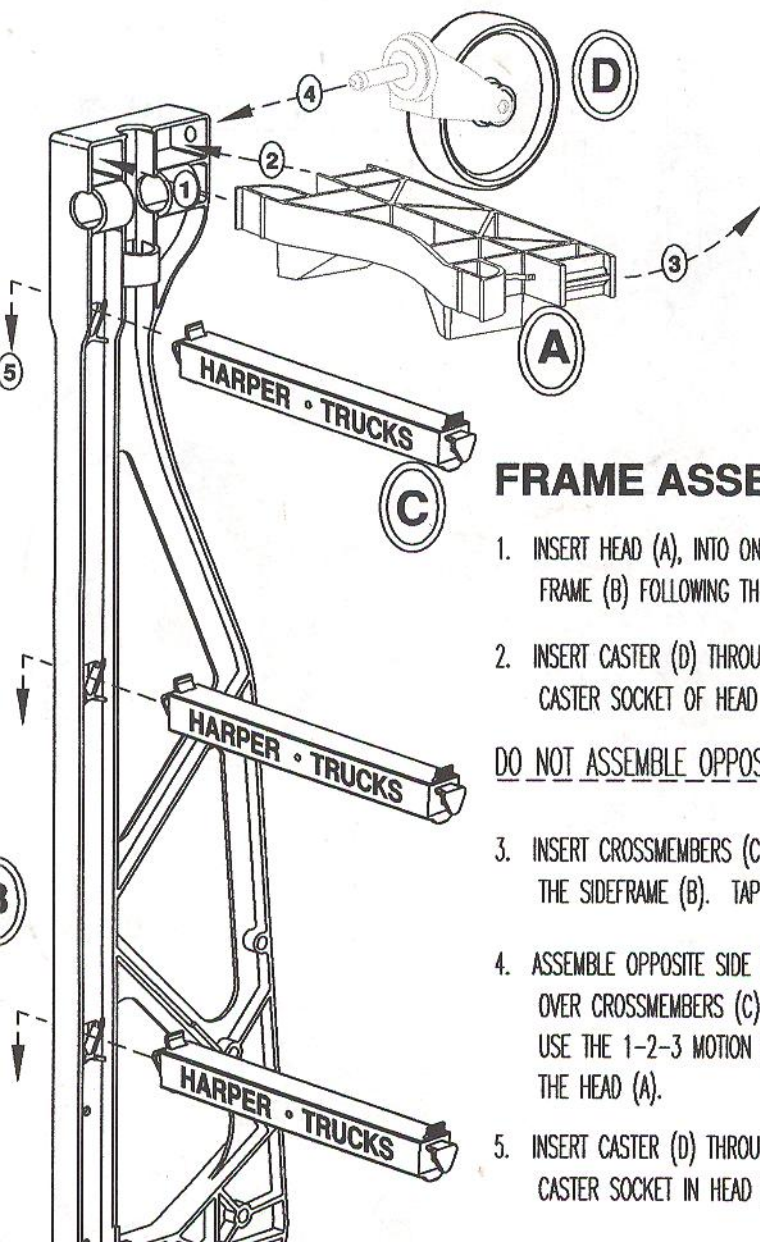

### FRAME ASSEMBLY

1. INSERT HEAD (A), INTO ONE SIDE FRAME (B) FOLLOWING THE 1-2-3 MOTION.
2. INSERT CASTER (D) THROUGH SIDE FRAME (B) & CASTER SOCKET OF HEAD (A).

DO NOT ASSEMBLE OPPOSITE SIDE AT THIS TIME!

3. INSERT CROSSMEMBERS (C) WITH NAME FORWARD, INTO THE SIDEFAME (B). TAP DOWNWARD LIGHTLY TO SECURE TABS.
4. ASSEMBLE OPPOSITE SIDE FRAME (B1) OVER CROSSMEMBERS (C) & HEAD (A). USE THE 1-2-3 MOTION TO INSTALL OVER THE HEAD (A).
5. INSERT CASTER (D) THROUGH SIDE FRAME (B1) & CASTER SOCKET IN HEAD (A).

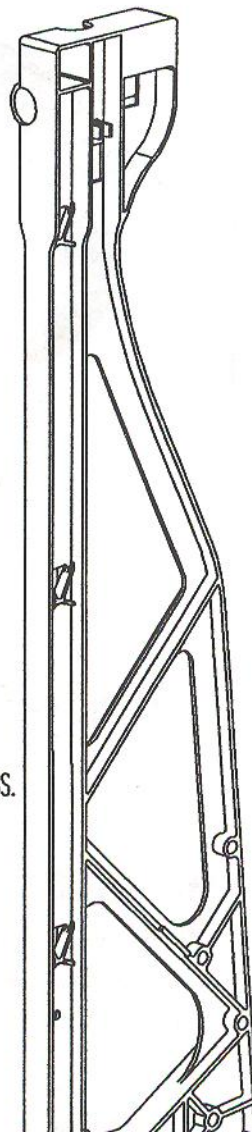

# BASE/AXLE ASSEMBLY

1. FASTEN THE BASE PLATE (E) TO THE FRAME WITH 4 BOLTS (F) AND NUTS (G).

2. SLIDE AXLE (H) THROUGH SIDEFRAPE (B) AXLE HOLES AS SHOWN. INSERT 2 WASHERS (K) ON THE AXLE BETWEEN THE FRAMES.

3. INSTALL 2 COTTER PINS (L) IN THE AXLE BETWEEN THE SIDEFRAPE WITH THE WASHER BETWEEN THE COTTER PIN AND SIDEFRAPE.

4. ASSEMBLE THE WHEELS ONTO THE AXLE WITH 2 WASHERS (K) ON THE INSIDE AND 1 WASHER (K) ON THE OUTSIDE OF THE WHEEL. SECURE WITH A COTTER PIN (L) THROUGH EACH END OF THE AXLE (H).

## PARTS LISTING

P/N	QTY	DESCRIPTION	P/N	QTY	DESCRIPTION
E	1	BASE PLATE	J	2	WHEEL
F	4	BOLT	K	8	WASHER
G	4	NUT	L	4	COTTER PIN
H	1	AXLE	M	1	HANDLE
			N	2	LOCK PIN

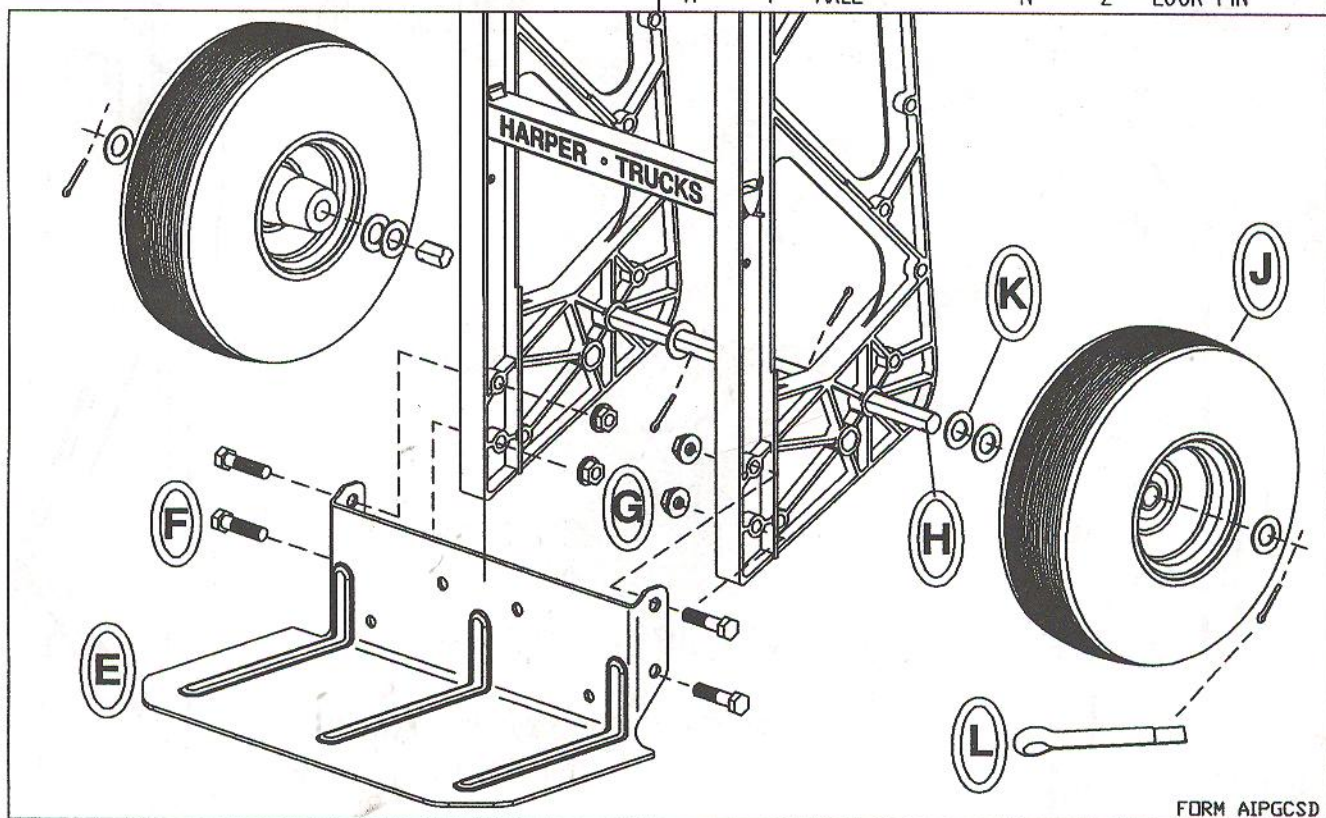

## HANDLE OPTIONS:

### TWO WHEELED HANDTRUCK

1. SLIDE HANDLE INTO FRAME HOLE (T) UNTIL UPPER HOLE ALIGNS.
2. INSERT LOCK PINS THROUGH HOLE (P) AND SNAP INTO FRAME CLIP.

### FOUR WHEELED HANDTRUCK

1. SLIDE HANDLE INTO FRAME HOLE (R) UNTIL UPPER HOLE ALIGNS.
2. INSERT LOCK PINS THROUGH HOLE (P) AND SNAP INTO FRAME CLIP.

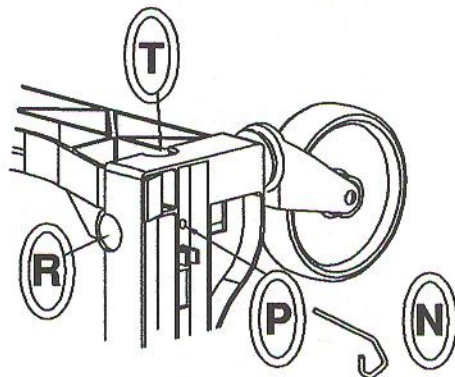

**Harper**  
TRUCKS Inc.

P.O. BOX 12330  
WICHITA, KS. 67277  
USA  
316-942-1381