

# HARPER TRUCKS INC.

## MODEL - PJD2223AD

1

### INSTRUCTIONS

#### PARTS LISTING

QTY	DESCRIPTION	P/N
A	1 HEAD	PGDTBLK-6
B	2 SIDE FRAME	PJDBLK-2L & 2R
C	2 CROSSMEMBER	PGBLK-5
D	2 CASTER	WH 23A

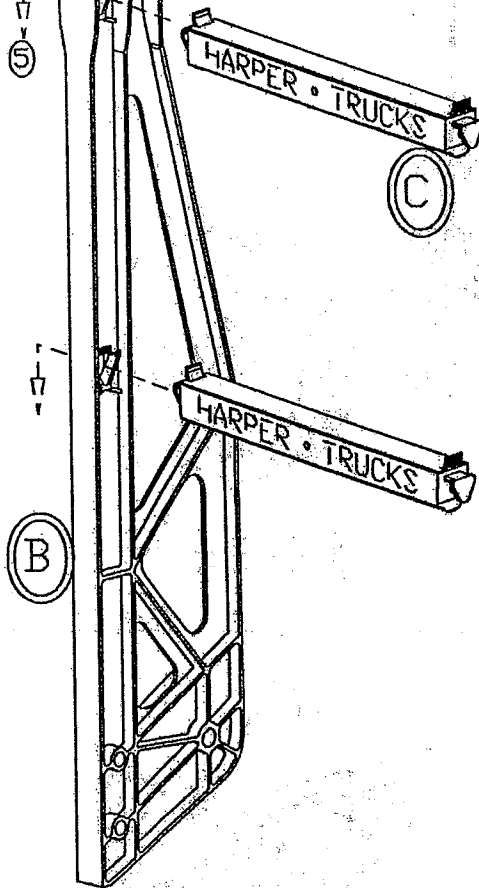
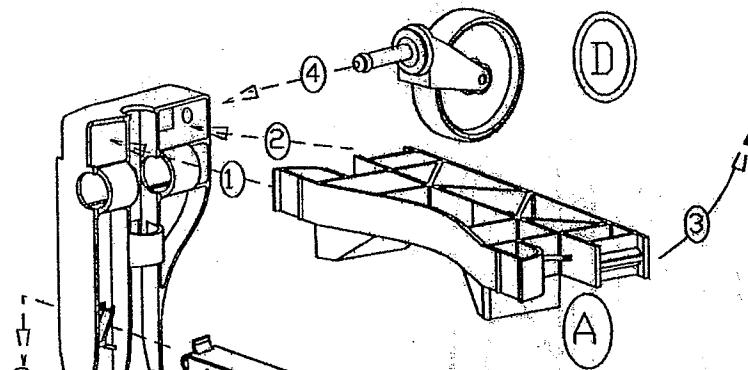

#### FRAME ASSEMBLY

1. INSERT HEAD (A), INTO ONE SIDE FRAME (B) FOLLOWING THE 1-2-3 MOTION.
2. INSERT CASTER (D) THROUGH SIDE FRAME (B) & CASTER SOCKET OF HEAD (A).

DO NOT ASSEMBLE OPPOSITE SIDE AT THIS TIME!

3. INSERT CROSSMEMBERS (C) WITH NAME FORWARD, INTO THE SIDEFRAME (B). TAP DOWNWARD LIGHTLY TO SECURE TABS.
4. ASSEMBLE OPPOSITE SIDE FRAME (B1) OVER CROSSMEMBERS (C) & HEAD (A). USE THE 1-2-3 MOTION TO INSTALL OVER THE HEAD (A).
5. INSERT CASTER (D) THROUGH SIDE FRAME (B & B1) & CASTER SOCKET IN HEAD (A).
6. TAP DOWN ON CROSSMEMBERS TO LOCK IN PLACE.

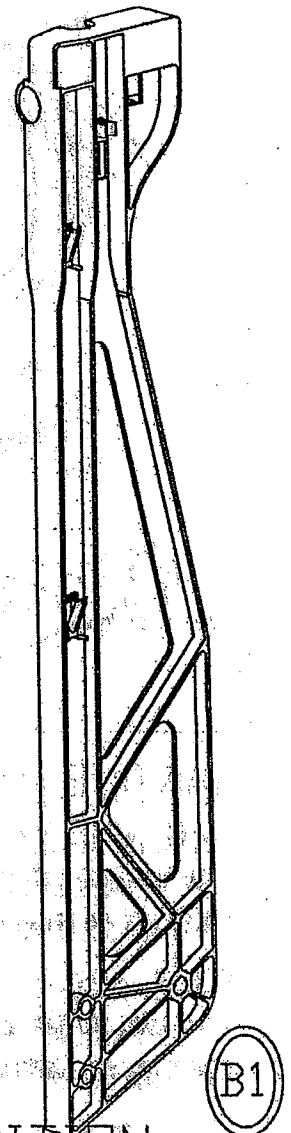

300 LBS CAPACITY IN 2-WHEEL POSITION

# BASE & AXLE ASSEMBLY

2

1. FASTEN THE BASE PLATE (E) TO THE FRAME WITH 4 BOLTS (F) AND NUTS (G).

2. SLIDE AXLE (H) THROUGH SIDEFRAME (B) AXLE HOLE AS SHOWN.

3. ASSEMBLE THE WHEELS ONTO THE AXLE AND PLACE 1 WASHER (K) OUTSIDE THE WHEEL. SECURE WITH A COTTER PIN (L) THROUGH EACH END OF THE AXLE (H).

## PARTS LISTING

QTY	DESCRIPTION	P/N	QTY	DESCRIPTION	P/N
E	1 BASE	PBSABLK-1	J	2 WHEELS	WH 22
F	4 BOLT	HDW SC 3/8X1.5H	K	2 WASHER	HDW BU #1
G	4 NUT	HDW N MA15-15	L	2 COTTER PIN	HDW P 106-12
H	1 AXLE	AX 1/2N15	M	1 HANDLE	FAP PGDT-2
			N	2 LOCK PIN	HDW P PGDT

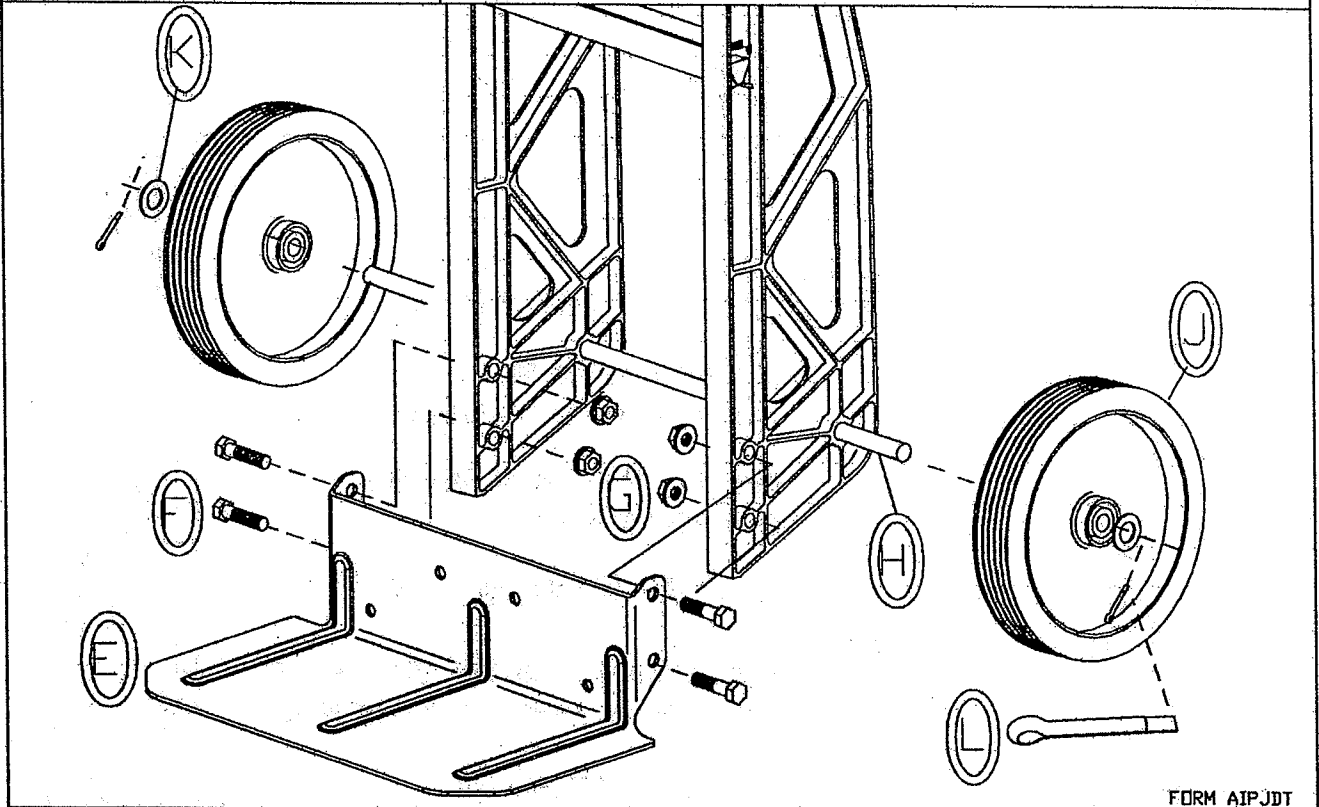

### HANDLE OPTIONS:

#### TWO WHEELED HANDTRUCK

1. SLIDE HANDLE INTO FRAME HOLE (T) UNTIL UPPER HOLE ALIGNS.
2. INSERT LOCK PINS THROUGH HOLE (P) AND SNAP INTO FRAME CLIP.

#### FOUR WHEELED HANDTRUCK

1. SLIDE HANDLE INTO FRAME HOLE (R) UNTIL UPPER HOLE ALIGNS.
2. INSERT LOCK PINS THROUGH HOLE (P) AND SNAP INTO FRAME CLIP.

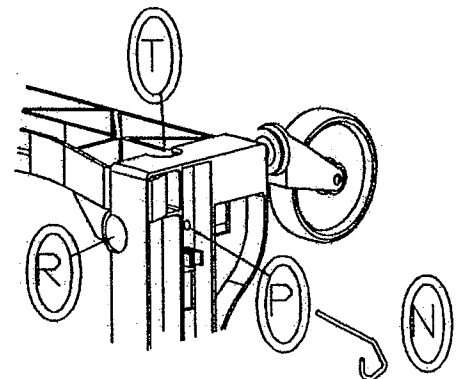

**Harper**  
TRUCKS Inc.

P.O. BOX 12330  
WICHITA, KS. 67277  
USA  
316-942-1381