

SC-304/2436 SERVICE CART ASSEMBLY INSTRUCTION

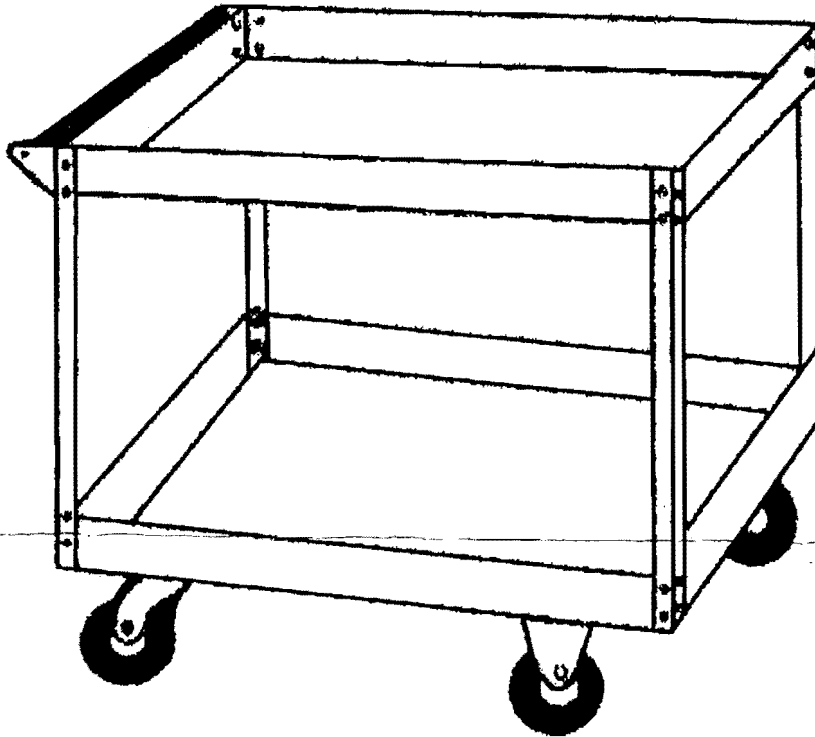

WARNING: Read this instructions before assembly.

Assembly Procedure:

1. Attach the swivel/fixed casters to the bottom tray using (16) M8x16 cap screws, (32) M8 flat washers, (15) lock washers and (16) M8 hex nuts. Tighten all hardware
2. Attach the four metal supports to the bottom tray using (16) M6x12 cap screws, (32) M6 flat washers, (16) M6 lock washers and (16) M6 hex nuts. Leave hardware loose until top tray has been installed
3. While installing the top tray, attach the handle to the same end that has the swivel casters. Use (16) M6x12 cap screws, (32) M6 flat washers, (16) M6 lock washers and (16) M6 hex nuts.
4. Tighten all hardware.

SC-304/2436 SERVICE CART PARTS DIAGRAM

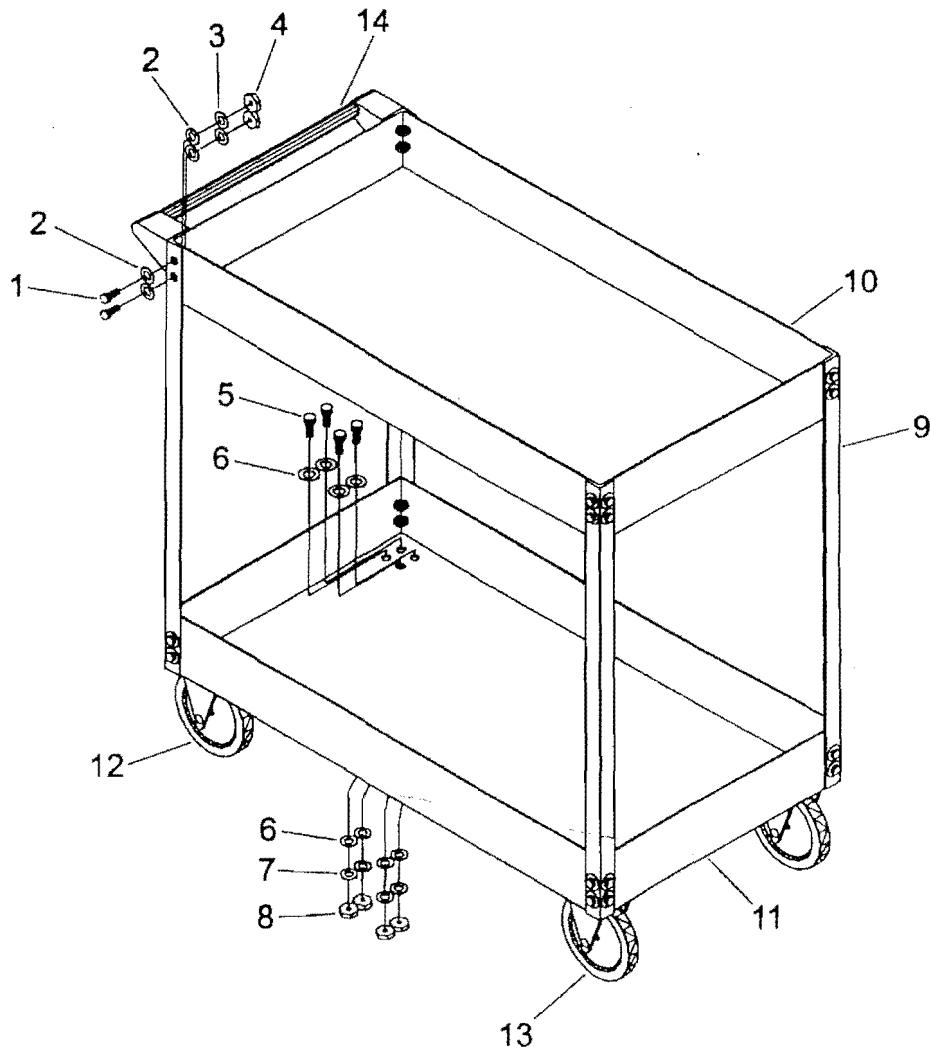

Parts List

No.	Description	Size	Quantity
1	Cap screw	M6x12mm	32
2	Flat Washer	M6	64
3	Lock Washer	M6	32
4	Hex Nut	M6	32
5	Cap Screw	M8x12mm	16
6	Flat Washer	M8	32
7	Lock Washer	M8	16
8	Hex Nut	M8	16
9	Metal Support		4
10	Top Tray		1
11	Bottom Tray		1
12	Swivel Caster		2
13	Fixed Caster		2
14	Handle Assembly		1